

REDFOOT[®]

LEVELLING



24V EQ Smart-Level Installation Manual

Updated: August 2024

Before starting the installation, check the content of all boxes received against the picking slip which is attached to the outer of the main carton. Please call Redfoot® Levelling immediately if there is a discrepancy!

WARNING!

This is a 24VDC System **DO NOT** connect to your 12Volt House Battery

Warning:

Redfoot Levelling does not promote the use of our levelling systems as a 'Tyre Jack' solution. If the owner/user were to use the levelling system to lift the vehicle off the ground to have access underneath the vehicle or for changing a tyre, they must use Jack Stands as the primary support. Jack Stands should be always in use as the primary support when wheels are off the ground for long durations.

Modification of any factory-supplied item may result in the denial of all warranty claims. Call Redfoot Levelling Solutions Technical Support prior to any modifications. Redfoot Levelling Solutions offers full installation support for authorised approved Installers only. End user installers must read and accept our Warranty and Terms and Conditions on the Invoice issued with this purchase.

Danger:

With any hydraulic application, holding position on a cylinder must be done with safety in mind. System failure may cause the jack(s) to retract or extend suddenly. When working under or near the vehicle, always use jack stands of appropriate rating to support the weight of the vehicle.

Contents

Tools Required for Installation	4
Additional Items Required for Installation.....	4
Installing the Cylinders	5
Installing the Pump	7
Installing the Fittings	8
Installing the feet.....	10
Installing the Hoses.....	11
Installation of Hoses to the Manifold.....	11
Wiring Harness	13
<i>Pump harness connections</i>	14
<i>Chassis Interface Connections</i>	14
<i>Keypad Park Brake Circuit</i>	14
<i>Power Connections</i>	15
Redfoot Levelling EQ Smart-Level.....	17
<i>Control Panel Programming</i>	17
<i>Orientation Setting</i>	17
Purging the Cylinders of Air	19
Manual Override	20
<i>7702 MO Pump</i>	20
Setting the Null.....	21
Troubleshooting Guide.....	22
Product Warranty Guide Redfoot Levelling Pty Ltd.....	24

Tools Required for Installation

- Ratchet, sockets, and spanner set
- Wire cutters / crimpers
- Electric drill and impact
- Drill bits and impact sockets
- Welding equipment (if welding leg or bracket in place)

Additional Items Required for Installation

- # 4 AWG power wire (to connect battery +24V positive to the pump) *
- # 4 AWG ground wire (to connect battery -24V ground to pump) *
- # 4 AWG ring terminals
- Loom clips/ Cable Ties (to secure harnesses and hydraulic hoses to the coach)
- Self-tapping screws or pop rivets
- Circuit breaker (see table below)
- Dexron II or III Automatic Transmission Fluid (see table below)**

Pump	Amps
7702MO	150

Pump	Volume
7702MO	10 - 16 Lt

Note: These items must be # 2 AWG if cable run is greater than 4 meters

* It is most important that these cables meet 6.5 mm or cross-section of 33.6 mm² (Australian Standard).

** Fluid volume may vary depending on vehicle size and cylinders being installed.

Installing the Cylinders

Determine where the cylinders are to be mounted. The cylinders must be mounted to the chassis frame, as close as possible to the front and rear axles. We advise that to optimize departure clearance, mount the cylinders within 1 meter of each axle.

Secure the cylinders brackets in place according to the bracket mounting drawings.

2.2 DRILLS ON THE CHASSIS

Installation of auxiliary equipment onto the chassis must be done using the factory drilled holes whenever possible.



- **It is strictly forbidden to drill holes into the side member flaps, with exception to what is indicated in Chapter 3.3 - Paragraph "Choosing the type of connection".**

When new holes must be made for specific applications (installation of shelves, corner shelves, etc.), these must be drilled into the upright rib of the side member and must be thoroughly de-burred and bored.

Hole position and size

The new holes must not be drilled into the areas subjected to greater stresses (such as spring supports) or where the side member section varies.

Hole diameter must be suited to sheet metal thickness but cannot exceed 13 mm (unless otherwise stated). The distance of the axis of the holes from the edge of the side member must not be less than 30 mm; in the same way, the axes of holes must not be less than 30 mm from each other or from other existing holes.

The holes must be offset as in Figure 2.

The original hole layout must be maintained when moving spring supports or crossbars.

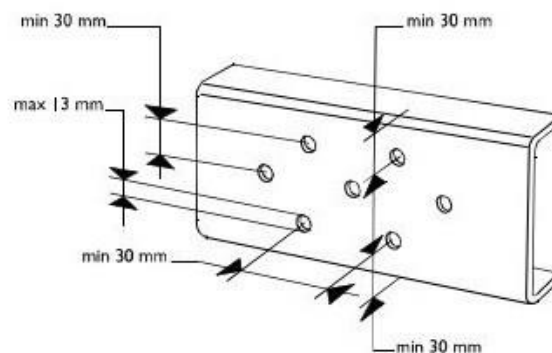

Bolt the cylinders to the bracket using the supplied serrated flanged bolts and nuts, do not use washers with serrated flanged hardware torque these to 77Nm (57lb-ft). The cylinders must be installed with a minimum of 200mm of ground clearance. See Installation chart below. The bottom of the footpad should be no lower than any other item mounted on the vehicle. On some extremely low vehicles there are provisions to mount lower than the recommended 200mm, as long as the foot does not impede the departure clearance angle. Pay attention to the angle of departure for the chassis when mounting the rear cylinders – and the angle of approach when mounting the front cylinders.

Table 1: Ground clearance reference chart for installing jacks by cylinder type

Standard cylinder		Telescopic cylinder	
13"	180-230mm	320mm	180-230mm
15"	200-250mm	600mm	Vehicle specific
16"	220-280mm	1070mm	
18"	250-300mm		
24"	350-400mm		

Note: Lower value of reference range refers to clearance from the bottom of foot to the ground.

Figure 1. Ground clearance reference chart

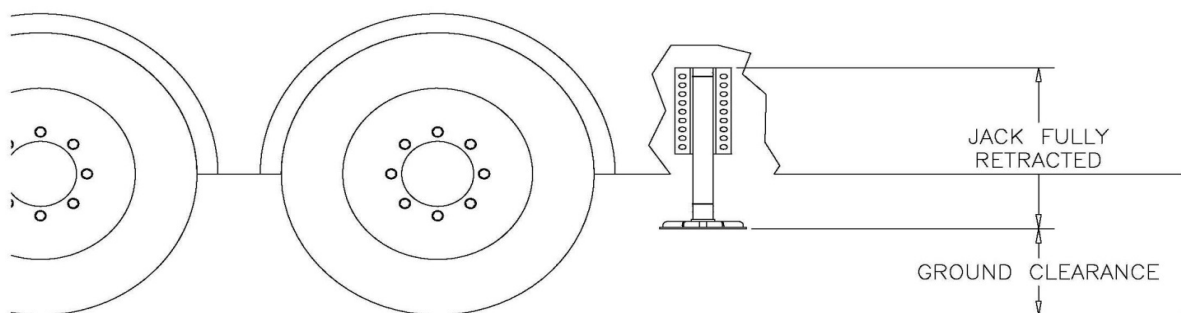

If in doubt call Redfoot Levelling (07) 3286 1199.

Installing the Pump

The pump must be mounted in a location that is reasonable to route all the hydraulic hoses to the manifold. It must be accessible for filling the reservoir and monitoring the fill level. Take note if the unit is equipped with the manual override option.

The pump emergency pump lever, cartridge valves and directional valves (if installed) are to be accessible to manually override the system. If the pump is equipped with the manual override pump lever on the end of the motor, then be sure to allow access to that end of the pump. (See figure below). In most applications, a side storage compartment will provide the ideal location. An additional mounting box or tray may be used on other motorhomes/buses.

Figure 2. 7702 MO Pump

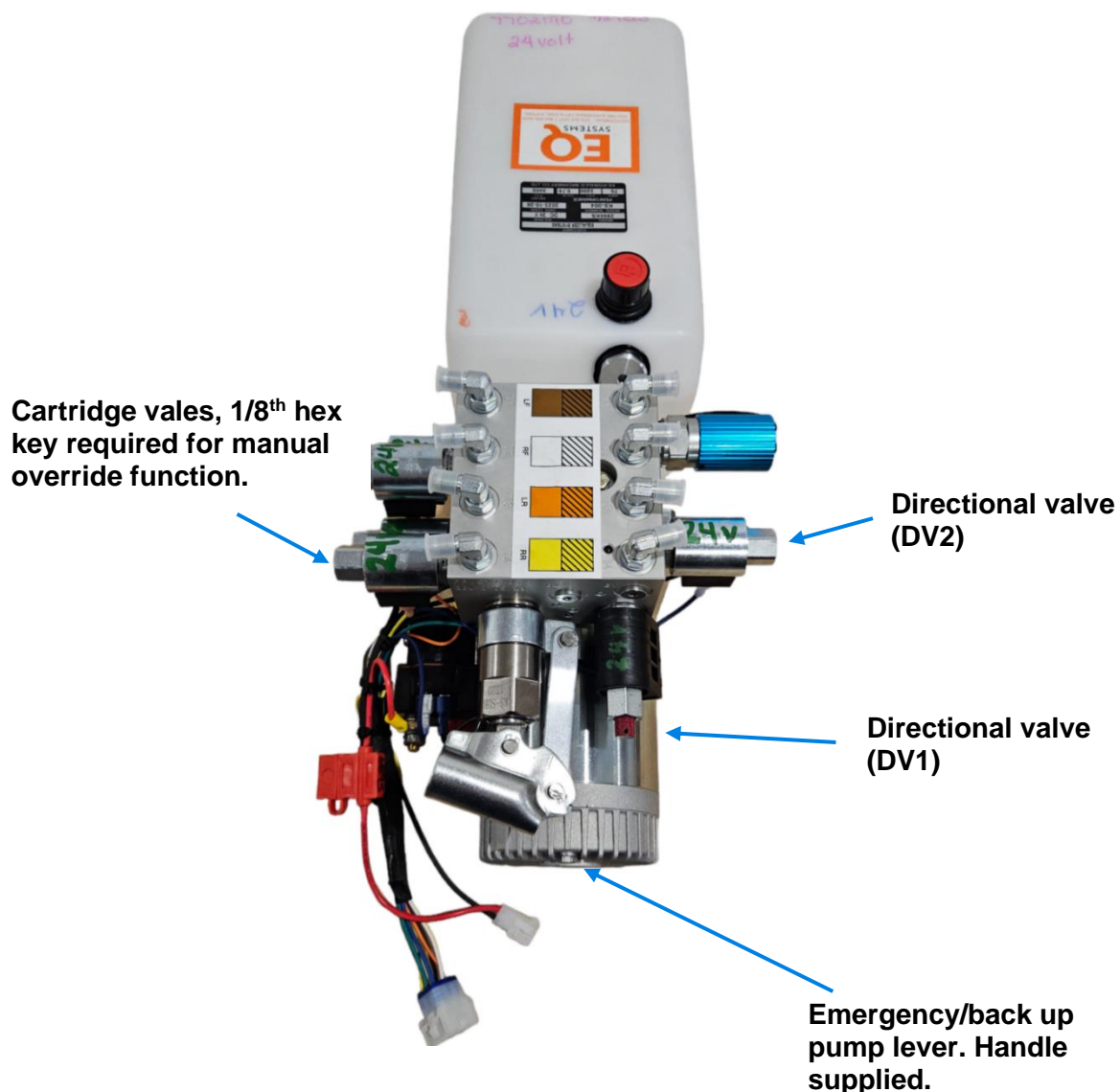

Installing the Fittings

Install the hydraulic adaptor fittings in the top and bottom of each jack and install the fittings into the manifold. The straight thread O-ring side always goes to the cylinder or manifold. The tapered side will get the hose attached to it.

When installing UNO fittings into the leg or manifold, tighten to 15 lbs.-ft, these are O-ring sealed do not use any sealants**. When using JIC fittings, turn until finger tight*, position correctly, then tighten the jam nut until slightly firm then another 30°. These are flared, do not use any sealants**.

*Over tightening can cause damage to the fitting. **Sealant is not required when using O-ring or 37° flare fittings

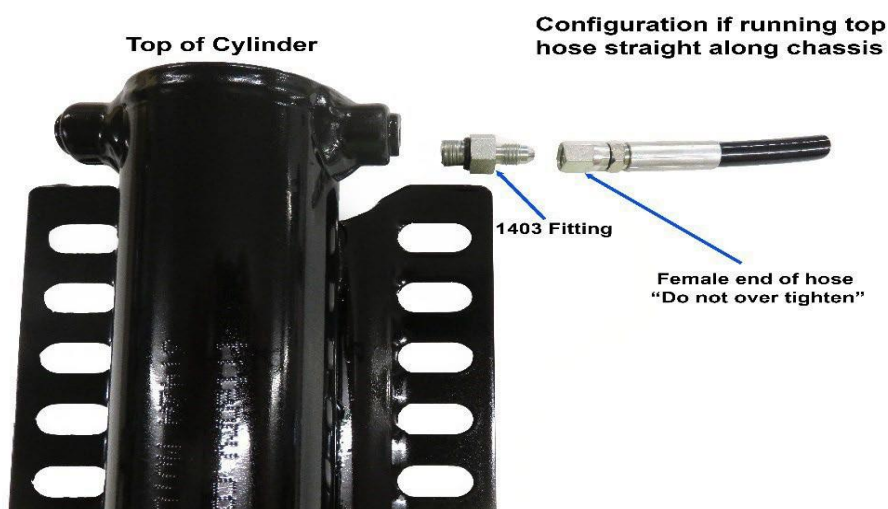
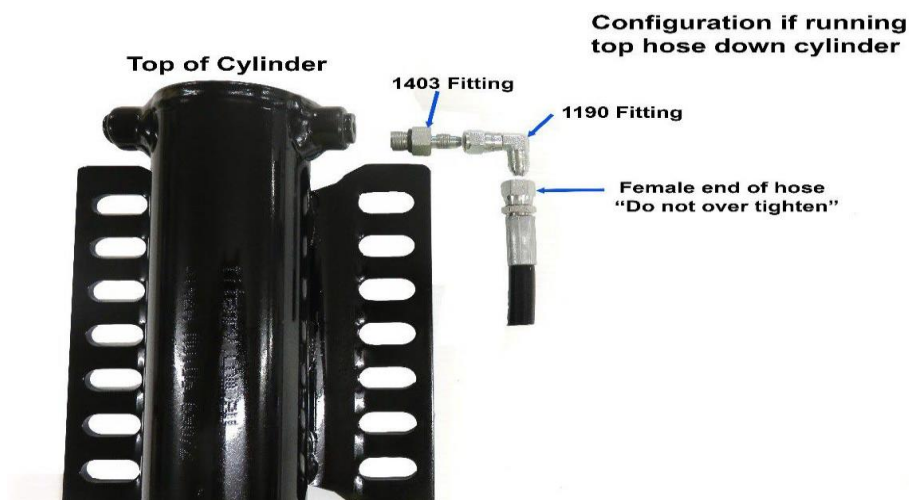



Installing the feet

When installing the feet make sure to use an impact gun with the correct sized socket. Using a wrench will cause the cylinder to spin and not allow the nylock threads to secure on correctly. Redfoot recommends using a product like Loctite if there is not a nylock insert.



Step 1. Extend cylinder approx. 1 inch before attaching foot.



Step 3. Check the rod thread is exposed once the nylock nut is tightened. *For nylock bolt make sure it is recessed into the foot plate.* The foot plate is secured with minimal movement on extensions and no movement when retracted.



Step 2. Use an impact wrench to secure nut or bolt in place.

Installing the Hoses

Install the hydraulic hoses so that they are clear of all hot exhaust components and pinch points in the suspension/chassis system. Attach the hoses to the pump manifold and cylinder fittings. Incorrect plumbing will cause operating problems at start-up.

Tighten the jam nut until slightly firm then another 30°. Secure the hydraulic hoses with cable ties or loom clamps to the chassis. Care should be taken to not kink or twist hoses. The minimum bend radius is 6 inches (150mm).

Tighten the jam nut until slightly firm then another 30°. Secure the hydraulic hoses with cable ties or loom clamps to the chassis. Care should be taken to not kink or twist hoses. The minimum bend radius is 6 inches (150mm).

Installation of Hoses to the Manifold

Jack Leg	Manifold Connection
Left Front-Top	T-1 Brown Solid
Left Front-Bottom	B-1 Brown Stripe
Right Front-Top	T-2 White Solid
Right Front Bottom	B-2 White Stripe
Left Rear-Top	T3- Orange Solid
Left Rear-Bottom	B3- Orange Stripe
Right Rear-Top	T-4 Yellow Solid
Right Rear-Bottom	B-4 Yellow Stripe

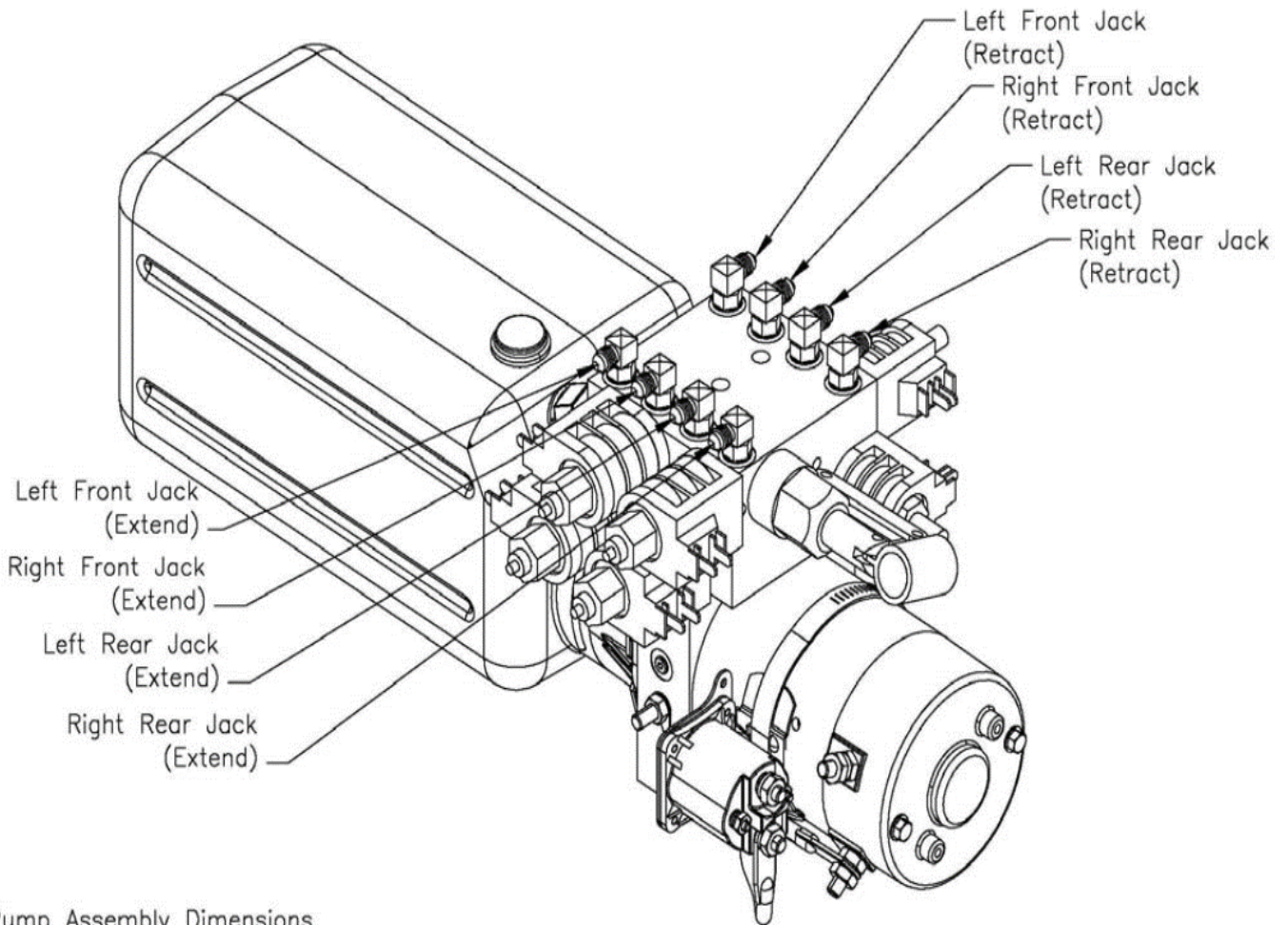

Pump Assembly Dimensions
Length-24"
Width-11"
Height-10"

Wiring Harness

Route the wire harness from the pump assembly to the area where the control panel is to be mounted. The harness needs to be routed away from moving objects, sharp edges, and high heat sources. Use cable ties and or loom clamps to secure in place.

The end with the 9 pin and 2 pin connector goes to the pump assembly. See the drawing for the layout. Connect the harness connectors to the matching connectors at the pump assembly.

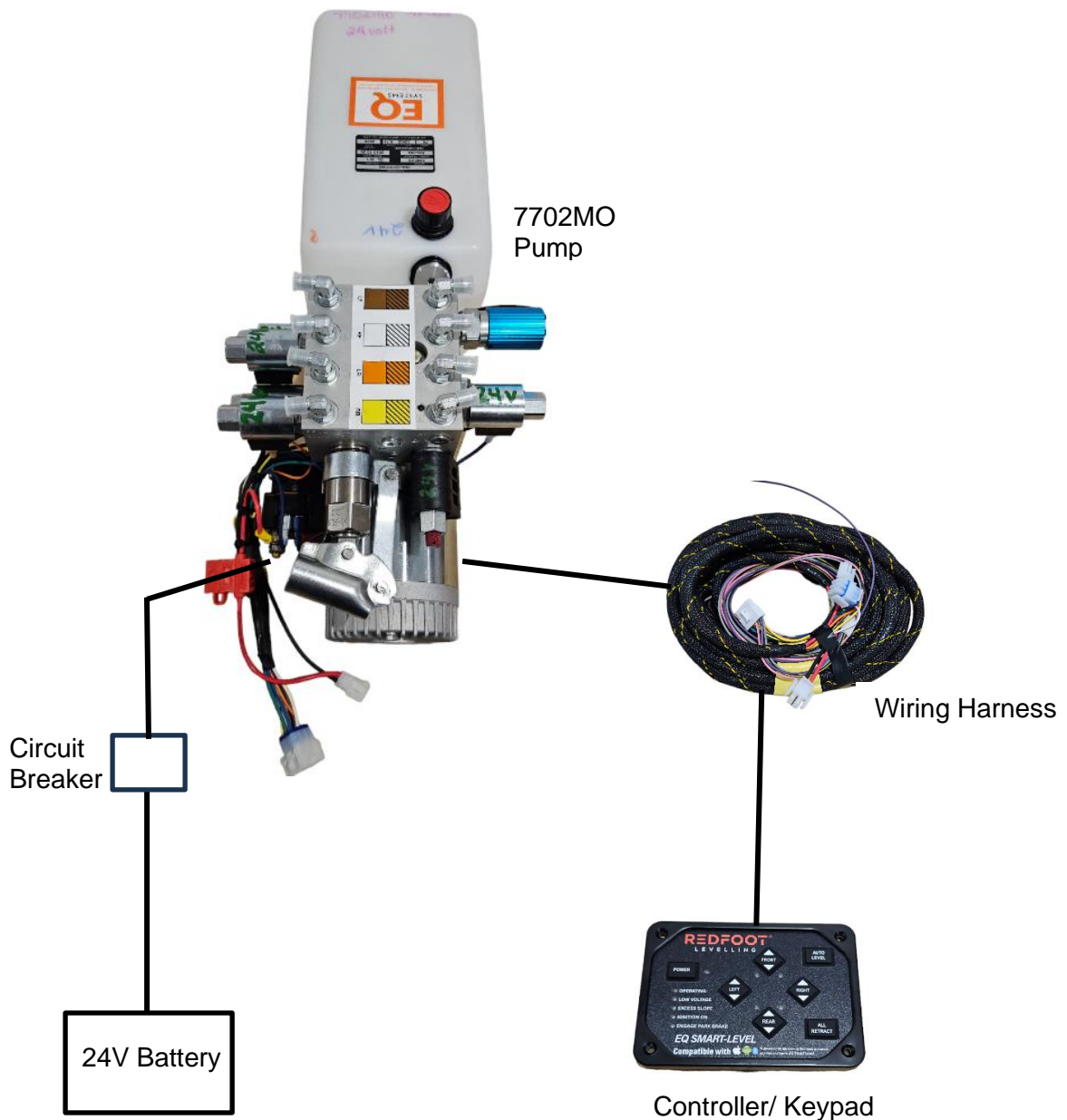

Pump harness connections

Attach the supplied wire harness between the pump and the location of the controller. This harness will connect between the pump and the mating connector on the controller. Note the harness breakouts for the main harness at the hydraulic pump. There are (2) ea. connectors for the jacks. Plug each connector from the harness into the corresponding connector on the pump. Secure the harness with wire ties or loom clamps to the chassis. You shouldn't have any disconnected plugs. All the connections at the pump should be completed except the main power and ground connections at the pump which are completed last.

Chassis Interface Connections ("breakouts" near the end of the keypad harness)

Keypad Ignition Disable Circuit

In most vehicles the pink wire will receive a +24 VDC input when the ignition key is in the "on" position. Connecting this wire to the ignition positive will make the wire 'hot' and will inhibit cylinder extension when the vehicle ignition key is in the on (engine run) position. This also provides for a "cylinders down" warning in the event of a jack drifting from the stowed position during travel.

Keypad Park Brake Circuit

The black w/ yellow wire must receive a ground input to indicate the park brake is active. If this is not grounded an alarm will sound on the keypad and will be inoperable. This is only necessary if you have a park break indicator on your vehicle, otherwise this black w/ yellow wire must be grounded to a permanent chassis ground.

Suspension deflate/Inflate: If chassis is equipped - There are two additional wires that break out from the harness near the keypad (if supplied). The grey wire provides a 24 VDC positive output for 2 minutes when the auto level button is pressed. This may be used to deflate the chassis air suspension. The Purple wire will provide a 2 minute 24 VDC positive output when the all-retract is pressed. This may be used to inflate the chassis air suspension. The Chassis must be equipped with an electric dump/inflate system for this interface. Check with the chassis manufacturer for the availability of this and the chassis side of this interface. If the chassis is not equipped or it is not to have this option, tape the 2 wires back to prevent shorting (do not use).

Power Connections

Attach a # 4 AWG wire (# 2 AWG if the run is over 13 feet - 4 meters) between the +24V terminal on the battery and the battery post at the motor solenoid on the pump. The solenoid post will generally have a yellow fused wire attached to it that supplies power to the controller. This battery connection may be fused at the source with a circuit breaker/ fuse. This +24V supply must be a dedicated and isolated circuit (not shared with any other device) and must be constant, non-switched +24V.

Attach a # 4 AWG wire (# 2 AWG if the run is over 13 feet - 4 meters) between the -24V terminal on the battery and the ground stud on the pump. This ground stud is located on the port plate on the pump. This is the preferred method of grounding. If grounding the pump to the chassis, the connection must be sound, free of paint and not susceptible to corrosion. It is not acceptable to allow the pump mounting bolts to be the sole grounding connection.

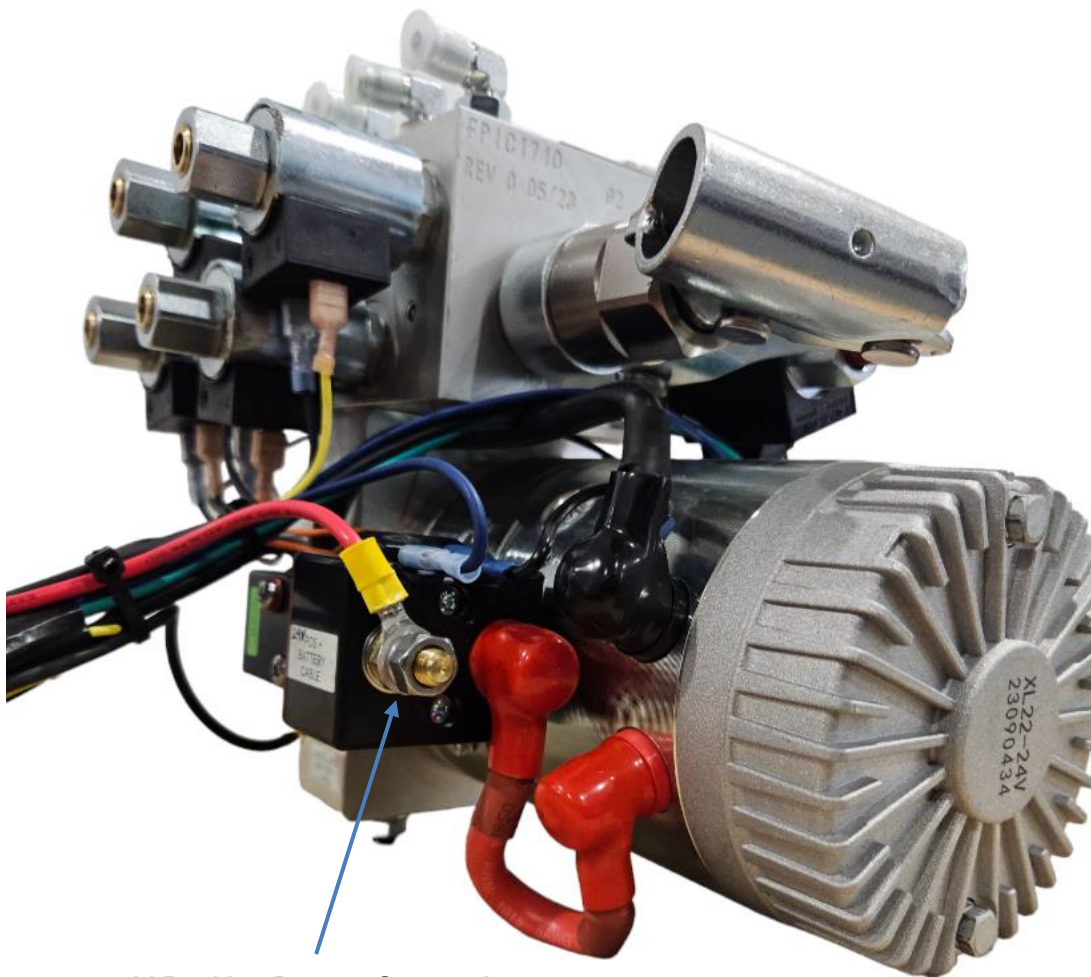

24V Positive Battery Connection

24V Negative Battery Connection

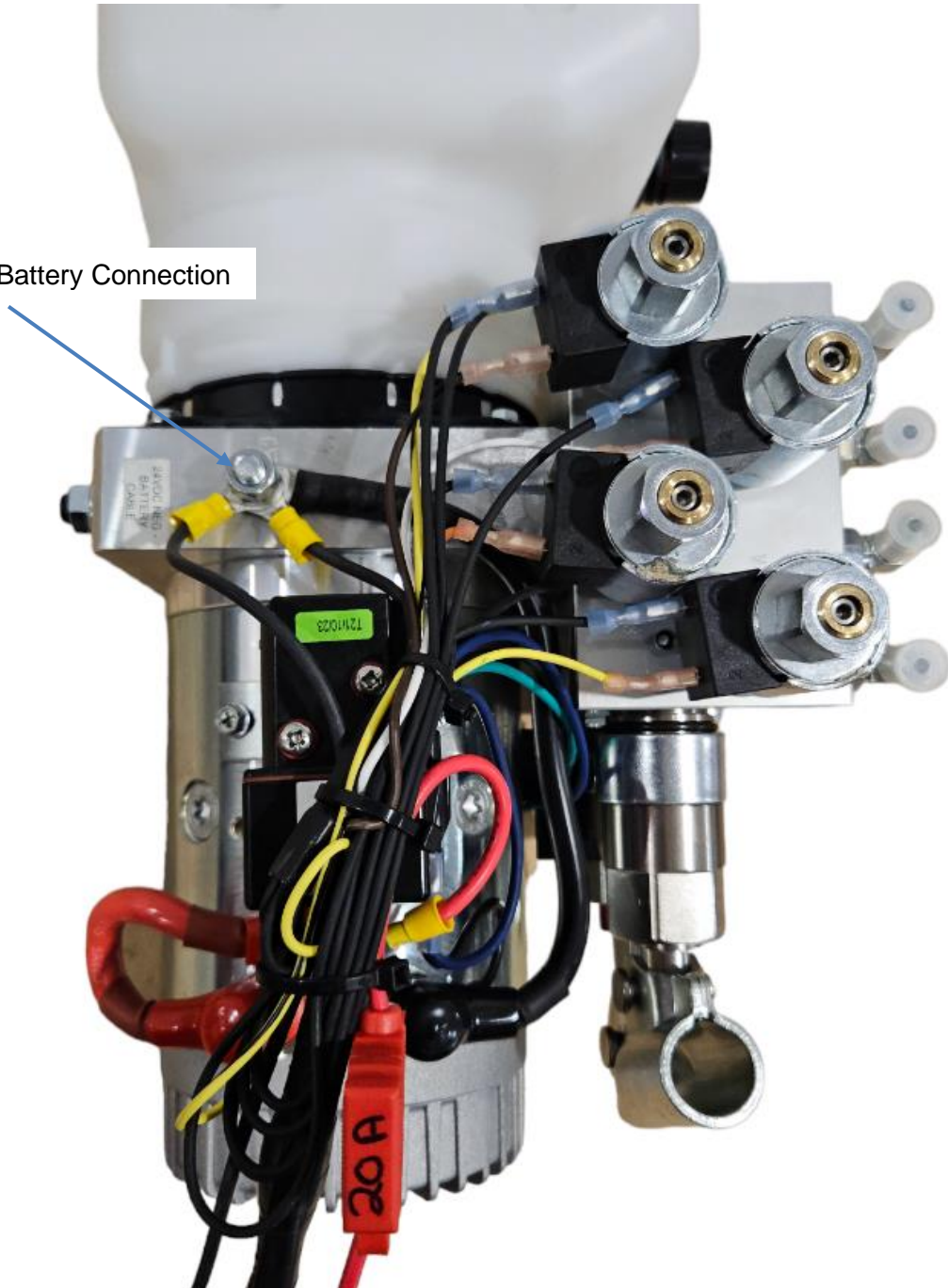

Redfoot Levelling EQ Smart-Level

Control Panel Programming

After the system is fully installed the control panel must be programmed for operation. Failure to do this will result in a failed or improper Auto-Level. There are basically two program settings, the orientation setting and the null setting that must be done in the following order.

Orientation Setting

This process cannot be completed until after the system has been connected to power and the control panel has been mounted and all electrical harness connections have been completed. This process teaches the control panel where the front of the coach is and how the control panel is mounted, either vertical (wall mounted) or horizontal (Benchtop mounted). If this process is not performed correctly the controller will not know where the front of the coach is. It is possible that without doing this process it may work on a level floor/shop environment however when at sites where the system needs to operate specific legs for leveling it very likely will operate the improper legs. Once this process is properly completed the setting will be “retained” in the control panel and shouldn’t be needed to set again.

With the control panel off press and hold the ‘all retract’ button then while holding press the power button, release both buttons. The power light will start blinking and you will hear a rhythm beeping, also the 4 jacks down indicator lights will be on. Next the orientation is selected by pressing one of the manual control arrows. The exact specific one is determined by how the panel is mounted (see examples below). You will select an up arrow if the panel is mounted vertically and a down arrow if it is mounted horizontal. The specific one is the one that most relates to the front of the coach.

Examples:

If the panel is mounted vertically on a wall/ cabinet so that when you are facing it, you are looking towards the rear of the vehicle then you would press the rear up arrow.



If the panel is mounted vertically on a wall/ cabinet so that when you are facing it, you are looking towards the front of the vehicle then you would press the front up arrow.



Note: if you are not clear on this process check our web site for video and/or call Redfoot Levelling for assistance.

Purging the Cylinders of Air

Please note, this procedure must be strictly followed. Any deviation from the process will cause the purging process to become difficult and time consuming.

1. Fill pump reservoir to full approx. 1 to 1 ½ inch from top with automatic transmission fluid, the multipurpose or any of the Dexron/Mercon fluids will work.
2. Using the manual switch for the front jacks extend the front jacks until they make ground contact. Do not lift the vehicle. If the vehicle is on a lift the jacks may be fully extended. Note: extend is the arrow pointing down.
3. Press all retract switch. After the front jacks have fully retracted and the pump shuts off check the reservoir fluid. Refill to full approx. 1 to 1 ½ inch from top.
4. If the fluid in the reservoir is aerated or foamed up, allow time for foam/air to dissipate before continuing. Allow 10 minutes for foam and air to dissipate.
5. Using the manual switch for the rear jacks extend the rear jacks until they make ground contact. Do not lift the vehicle. If the vehicle is on a lift the jacks may be fully extended.
6. Press all retract switch. After the rear jacks have fully retracted and the pump shuts off check the reservoir fluid. Refill to full approx. 1 to 1 ½ inch from top.
7. If the fluid in the reservoir is aerated or foamed up, allow time for foam/air to dissipate before continuing. Allow 10 minutes for foam and air to dissipate.
8. Using manual switches extend to full extension of front and rear jacks. At this point jacks may be allowed to lift the vehicle. Allow 10 minutes for foam and air to dissipate.
9. Press all retract switch. After the jacks have fully retracted and the pump shuts off check the reservoir fluid. Refill to full approx. 1 to 1 ½ inch from top. Allow 10 minutes for foam and air to dissipate.
10. Check fluid level. Fill to full 1 to 1 ½ inch from top.
11. Repeat steps 7 through 10.

Manual Override

7702 MO Pump

Refer to Figure 2. This pump is equipped with a manual override. Locate the 4 valves on the left side of the manifold. Locate the screws recessed at the end of the appropriate cartridge valves. Using a 1/8th hex Key, turn the screw(s) clockwise until seated in.

Using a 1/8th hex key, turn the recessed screw on the DV2 cartridge clockwise until seated.

Turn and pull the red DV1 valve to approx. 180 °, this will allow the pump to be in retract mode.

The valve knob will remain in the out position.

Place the pump handle into the emergency pump lever at the front of the pump. Crank the handle several times until all legs have retracted. This process will take some time to achieve full retract of the legs.

Caution!

Following manual override operation, failure to return all the valves to normal position may result in one or more of the jacks drifting down from their retracted position. Ensure all screws recessed

Setting the Null

Null is the term used to indicate the desired level outcome of the vehicle. The null has been preset at the factory but will most likely need to change. If the vehicle is not level following an attempt to Auto-Level, you will need to manually level it and reset the null. To set the null, push and release the Power button on the Keypad to engage power. The LED light next to the Power button should be RED when the power is on. Level the vehicle by deploying jacks manually, or by simply parking the vehicle on a level site. You do not need to have the jacks deployed to set the null. Use a bubble level on a flat surface in the centre (or close to) of the vehicle as a reference. Once the vehicle is level, turn the power off at the panel. Press and hold the Auto-Level button and press and release the Power button and listen for a series of beeps. After the Keypad has beeped 5 to 6 times, release the Auto Level button (the Keypad will continue to beep if the Auto-Level button is held). The new null has been set and the panel will maintain this setting. Press and release the All Retract button to retract the jacks to the stowed position. You will now be able to auto level to that set null.



Troubleshooting Guide

Symptoms	Possible Cause	Solution
Keypad will not turn on	Blown fuse at pump harness	Replace fuse 20A
	Faulty ground or 24VDC power	Trace and repair
	Low battery voltage - min. 21	Charge batteries
	Defective keypad or controller	Call Redfoot Levelling
	Defective keypad or controller harness	Trace and repair
Keypad turns on but jacks will not operate	Low battery voltage to pump	Charge batteries
	Faulty ground or 24VDC power	Trace and repair
	Defective keypad or controller	Call Redfoot Levelling
	Defective pump motor or solenoid	Replace motor and/or solenoid
	Other system defect	Call Redfoot Levelling
Jacks will extend but will not retract	Low battery voltage - min. 21	Charge batteries
	Park brake not set	Set Park brake
	If bi-rotational pump, bad motor or solenoid	Replace motor and/or solenoid
	Anti-twist software protocol has stopped further action	Lower opposite side of vehicle and/or reset Null and then level vehicle
	Ignition switch in wrong position	Check and change as needed
	Defective keypad or controller	Call Redfoot Levelling
	Faulty ground or 24VDC power	Trace and repair
	System defect	Call Redfoot Levelling
AUTO Level will not level	System Null is to set	Set Null
	Controller has been set wrongly or has moved	Check controller orientation
	Ignition switch in wrong position	Check and change as needed
	Damaged or defective keypad or controller harness	Call Redfoot Levelling
	Defective keypad or controller	Call Redfoot Levelling
	Other system defect	Call Redfoot Levelling

Troubleshooting Guide		
Symptoms	Possible Cause	Solution
Auto-Level stops mid-cycle	Low battery voltage - min. 21	Charge batteries
	Excessive motion during leveling sequence	Reset keypad and retry
	Damaged or defective controller	Check and change if needed
	Damaged or defective keypad or controller harness	Call Redfoot Levelling
	Other system defect	Call Redfoot Levelling
Jack LED's on keypad staying on	Defective pressure switch or wiring	Trace/Repair or replace
	Defective keypad/controller or pump harness	Trace and repair or replace
	Defective keypad or controller	Call Redfoot Levelling
	Low system pressure caused by fluid leak or low fluid level	Correct fluid level or leak
Hydraulic pump inoperative	Low battery voltage - min. 21	Charge batteries
	Blown 20A fuse on pump harness	Replace fuse or breaker
	Faulty ground or 24VDC power	Trace/Repair or replace
	Defective pump motor or solenoid	Replace
Jack(s) bleed down from levelled or stowed position	Air in hydraulic system	Purge/bleed air
	External fluid leak	Trace and repair
	Defective valve in pump	Clean or replace valve
	Defective hydraulic jack/cylinder	Replace hydraulic cylinder
Jack(s) are jerky or noisy when extending or retracting	Air in hydraulic system	Purge/bleed air
	Fluid level low	Check fluid level and top up
Jack's will not retract from extended position	Low battery voltage - min. 21	Charge batteries
	Low battery voltage or poor ground	Change batteries/check ground return
	Damaged/Defective harness from keypad to controller or controller to pump	Trace and repair
	Fluid level low	Correct fluid level and add
	Defective pump motor or solenoid	Replace

Product Warranty Guide

Redfoot Levelling Pty Ltd

1. Only warranty claims with prior written or verbal authorisation from Redfoot Levelling will be recognised, all other claims will be denied.
2. Redfoot Levelling warrants levelling system components for a period of **one year** from the date of original sale of the vehicle. This warranty covers defects in material and workmanship only. Redfoot Levelling is not liable for any damage due to abuse, neglect, misuse, negligence, misapplication, error of operation, accidental or purposeful damage or damage due to an "Act of God" such as, wind or rain damage, flood, lightning or other natural causes of the like. Redfoot Levelling limited warranty is applicable to the Redfoot Levelling components only and does not apply to the vehicle, apparatus, or property to which it is attached. Warranty parts will be shipped at no charge if the repair is authorised by Redfoot Levelling representative. Purchased components used in authorised warranty repairs will be reimbursed at the original purchase price. All returns must be preauthorised by a Redfoot Levelling representative. Connotes will be supplied for their return unless prior arrangements have been made. Installers must receive and accept the appropriate Scope of Works from Redfoot Levelling prior to the commencement of any work.
3. Labour and freight expenses due to warrantable parts defects or workmanship will be reimbursed for the period of **one year** from the date of the original sale of the vehicle. Freight expenses will either be prepaid by Redfoot Levelling or reimbursed at the road logistic rate only. Any additional shipping charges or requirements are the obligation of the vehicle owner or service centre performing the warranty repair. The owner or Service Centre's obligation may include overseas shipping charges, border fees, and any other additional fee of the like.
4. Prior authorisation is required before parts may be returned to Redfoot Levelling. Redfoot Levelling will supply a connote for the return goods.
5. Labour, parts, and freight credit (if applicable) will be sent after the parts are tested and the warranty claim is validated. Returned parts that are found to be in normal operating condition are not warrantable and will be charged to the owner or service centre. Redfoot Levelling reserves the right to charge back the service centre for labour claim payments previously submitted if the installation of the warranted part is found to be inadequate later.
6. Warranty labour will be reimbursed only for claims that have prior written or verbal authorisation from a Redfoot Levelling representative. Time associated with learning about the repair or excessive diagnostic and installation time will not be reimbursed. Warranty labour will be reimbursed at the authorised service centre's published shop rate for that region. Overtime labour will not be reimbursed without exception.
7. Replacement parts are warranted under the same guidelines listed in this guideline for

the remainder of the original warranty or 90 days, whichever is longer. Proof of warranty repair date and original vehicle purchase date are required. No additional warranties expressed or implied are authorised by Redfoot Levelling.

8. All warranty works are to be completed and invoiced within 3-months of the Scope of Works date of issue.
9. Parts that are required to be returned to Redfoot Levelling, must be returned upon job completion and prior to warranty invoicing. Parts not returned within this period will be billed to the installer. Claims will be denied if the date submitted is greater than **30 days** from the repair.
10. Complete systems are not warranted unless authorised by a Redfoot Levelling representative. There are absolutely no exceptions to this clause.
11. Consideration should be taken regarding the location and protection of Redfoot Levelling's components prior to installation. Please reference our installation manuals for recommended locations and maintenance or visit www.redfootlevelling.com.au for more information. The failure of any Redfoot Levelling components due to extreme environmental conditions, improper installation or lack of maintenance will not be covered under the warranty.
12. Warranty coverage for parts or systems sold by non-authorised resellers will be at the discretion of Redfoot Levelling.
13. This warranty begins upon the sale date of the vehicle and is transferable, with limitation, subsequent owners are to provide the original sale date of the vehicle and proof of purchase.
14. Redfoot Levelling is not liable for loss of time, manufacturing costs, labour, material, loss of profits, direct or indirect damages incurred by the vehicle manufacturer.
15. Excessive warranty labour resulting from inadequate access to the Redfoot Levelling product will not be reimbursed.
16. Redfoot Levelling will not pay mark-up on warranty parts unless required by law.
17. Travel expenses, hotel, telephone, fuel, or any other expense of the like are not covered under the warranty.

No additional warranties expressed or implied are authorised by Redfoot Levelling.

Redfoot Levelling Pty Ltd
Unit 1, 7 Abeles Street
BARINGA QLD 4551
Ph: +61 7 5228 0211
Email: info@redfootlevelling.com.au

REDFOOT
LEVELLING